

# Person and Memory

Although psychology has become an established science, it still has deep connections to philosophy. This is particularly true when we consider the concept of person that is at the foundation of all psychology. A person exists (and persists) through the processes of consciousness and memory. The following [photograph](#) (by Marie-Lan Nguyen) shows a Roman statue of Clio, the muse of history, from the Museo Pio Clementino of the Vatican. Clio records what is happening and recalls what has happened. History ensures that the past persists. The past helps us to understand the present.



Clio, Museo Pio Clementino

The statue derives from the 2<sup>nd</sup> century CE. Its head and body were originally from different statues. Our knowledge of the person comes from both psychology and philosophy. This posting looks at memory and person from these two viewpoints. The photograph has been modified to provide more space on the

statue's right. There is much we do not know.

### **From soul to person**

The philosophers of the Enlightenment doubted the existence of the soul. Thoughts and sensations were all that could be directly experienced. These required a subject to experience them. In his *Essay Concerning Human Understanding*, Locke (1689) proposed the terms "self" and "person" for this subject. A person is

a thinking intelligent being, that has reason and reflection, and can consider itself, as itself, the same thinking thing in different times and places; which it does only by that consciousness which is inseparable from thinking, and, as it seems to me, essential to it; it being impossible for anyone to perceive, without perceiving that he does perceive. (Book II, Chapter 27)

As well as consciousness, the idea of person required a memory of one's past thoughts and actions. Consciousness of both past and present could then support the identity of the person over time. Without memory, each moment of experience would require a different subject:

For since consciousness always accompanies thinking, and it is that which makes everyone to be what he calls self, and thereby distinguishes himself from all other thinking things; in this, alone, consists personal identity, i. e. the sameness of a rational being; and as far as this consciousness can be extended backwards, to any past action or thought, so far reaches the identity of that person; it is the same self now, it was then; and it is by the same self with this present one, that now reflects on it, that that action was done. (Book II, Chapter 27)

Locke considered memory as a simple storehouse of perceptions that could be revived at a later time

this laying up of our ideas in the repository of the memory signifies no more but this, that the mind has a power in many cases to revive perceptions which it has once had, with this additional perception annexed to them, that it has had them before. (Book II, Chapter 10).

In this way, Locke considered the human mind as essentially passive: a clean slate (*tabula rasa*) upon which the world writes through the process of sensation, and an untended warehouse of slowly fading messages from the past.

Personhood clearly requires both consciousness and memory but the relationships are not simple (Behan, 1979). Am I a person when I am unconscious? Am I the same person as the two-year old child who grew up to be me, but whose experiences I can no longer remember? Personal identity must depend on physical as well as psychological continuity (Parfit, 1984; Olsen, 2010). In modern science we might also consider genetic continuity: over time our cells may change but our genes remain the same.

The self as described by the philosophers of the Enlightenment had a definitely moral aspect. Locke proposed that conscious memory must take responsibility for a person's past actions. The self

extends itself beyond present existence to what is past, only by consciousness,—whereby it becomes concerned and accountable; owns and imputes to itself past actions, just upon the same ground and for the same reason as it does the present. (Book II, Chapter 27).

Whereas the soul had existed in relation to God, the person was much more closely related to society. The Enlightenment was far more concerned with the rights and duties than with sin and salvation. Our modern concept of the person continues this idea of individual responsibility:

A person is a being with a certain moral status, or a bearer of rights ... a being who has a sense of self, has a notion of

the future and the past, can hold values, make choices; in short can adopt life-plans ... a being with his own point of view on things ... a being who can be addressed, and who can reply ... a 'respondent.'. (Taylor, 1985, p. 97)

## **Active Attention**

In his *Essay on Human Understanding*, written in reply to Locke's essay, Condillac (1746, reviewed by Kaitaro, 2007) pointed out that perception and memory are not simply passive responses to incoming sensation. Attention selects which of our sensations are perceived and remembered, and finds relations among these sensations. Furthermore, attention is purposeful, acting according to our needs.

The association of several ideas can only be caused by the attention which we have given them when they occurred together: as well, things only attract our attention because of their relation to our temperament, passions and state of mind, or, in a word, our need. (Condillac, 1746, Part I, Section II, Chapter 3)

One of the ideas that the human mind creates is that of the self. Condillac proposed that this comes about through a process that compares present perceptions with memories of past perceptions:

When objects attract our attention, the perceptions that they cause are associated with a feeling of self ... Consciousness not only is aware of our perceptions but also, if these repeat, informs us that we have already experienced them, and tells us how, despite their variety and succession, they relate to ... a being that is always the same. ... Without what I call *reminiscence*, each moment of our life would appear as the first in our existence, and our consciousness would never extend beyond our first perception. (Condillac, 1746, Part I, Section II, Chapter 1)

However, although Condillac considered consciousness as an

active process, he came to think that this activity itself could be derived from sensation. In his later book, *Treatise on Sensations* (Condillac, 1754, discussed in Falkenstein, 2010), he attempted to see how all of our thinking could come from sensation, using the concept of a statue that is sequentially stimulated in each modality. Though he disagreed with Locke about the passivity of the mind, he still decided that active mental processes could be derived from experience. Sensation teaches us to think. Nothing is innate.

However, as pointed out by Donald (2001), Condillac's statue cannot develop in this way unless it has from the beginning the ability to be conscious of the various sensations that it experiences. Furthermore, the statue would have to be endowed with some curiosity or there would be no motive for it to make any associations between the different sensations that it experiences.

Nevertheless, by the end of the book Condillac's statue has developed attention, perceptions, associations, memory and desire. Condillac appears to be stating that this statue is equivalent to a human being. Yet, although it has some idea of its own body, the statue does not have any clear understanding of itself. The statue's final soliloquy includes the haunting comment:

I see myself, I touch myself, in a word, I sense myself, but I do not know what I am. (Condillac, 1754, Part IV, Chapter 8)

This absence of any self-understanding may be related to the statue's lack of any social experience. Condillac provided it with sensations of itself and of objects, but not of other persons. The human concept of the self develops at the same time as the concept that there are other persons in the world each with its own consciousness and will (Wellman, 2011).

## **Cognitive Psychology**

Competing claims that human mental processes were passive or active played themselves out again in the 20<sup>th</sup> Century. Behaviorists proposed that all our actions derive from the stimuli that we receive. At mid-century, however, a cognitive revolution occurred: psychologists decided that human perception is an intensely active process, and that memory is far more complicated than a simple repository of experience.

Human memory is presently conceived as having short and long durations. Short-term memories include sensory stores which serve to register modality-specific incoming information, and working memory which selects information from these stores, and transforms it into action according to current needs and goals. Working memory has access to learned procedures and concepts that are maintained in long term memory, and uses various subsidiary stores, such as the phonological loop and the visuo-spatial scratchpad, to hold information while it operates.

The diagram below shows the general structure of human information processing, with the different human memories shown in separate boxes. Current cognitive psychology considers these memories as residing in neuronal networks that are far more widespread and overlapping than the diagram suggests. Attention is the process that selects what information is transferred into and out of working memory.

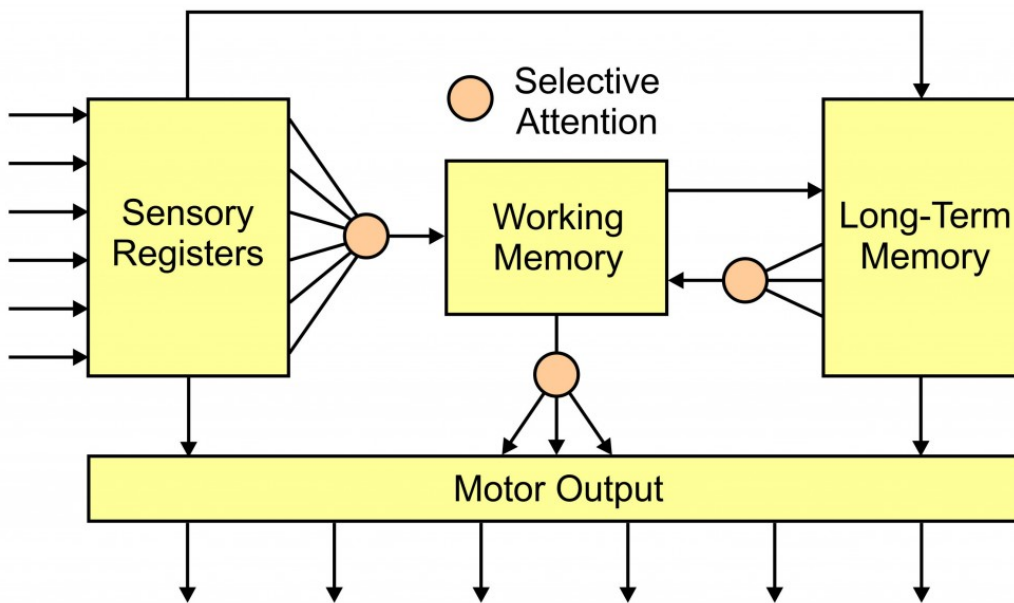

Long-term memory is what is usually considered as “memory” in everyday speech. Cognitive psychology divides this into explicit and implicit, depending upon whether the recalled information is accessible to consciousness. This distinction is also described as declarative vs. procedural. The memory of how to ride a bike is implicit/procedural; the memory of the capital city of France is explicit/declarative.

Endel Tulving (1972, 1983, 2002) proposed that explicit memory is further divided into two types: semantic and episodic. Semantic memory is the memory for facts. Such facts are recalled without any relation to our experience when we initially learned them. Episodic memories are recalled together with aspects of what we experienced when they were initially stored into memory, i. e., they are recalled as part of an episode in our life. The archtypical episodic memory is that of one’s first kiss, a memory that usually cannot be recalled without re-experiencing many attendant sensations and emotions. The following table (modified and abridged from Tulving, 1983, p. 35) gives some of the distinctions between the two types of memory:

**Feature**

**Semantic**

**Episodic**

Source	sensation
comprehension	
Units	events, episodes
facts, ideas	
Organization	temporal
conceptual	
Reference	self
universe	
Veridicality	personal belief
social acceptance	
Registration	experiential
symbolic	
Access	deliberate
automatic	
Retrieval queries	when? where?
what?	
Recalled information	personal past
facts	
Reported experience	remember
know	

Episodic memories are associated with a special type of consciousness that Tulving and his colleagues have called "autonoetic" (Wheeler et al., 1997). This allows us to re-experience events from the past without our becoming confused with our present experience. Remembering something is similar to the original experience but is clearly not the same. Autonoetic consciousness provides us with the ability for "mental time travel." Moreover, as well as letting us remember our past, it allows us to experience what might happen to us in the future.

One experimental technique for evaluating episodic memory involves having subjects recall previously learned associations. They are then asked whether they "remember" these items (on the basis that they also recall what happened when the association was studied), or simply "know" the



association (reviewed by Tulving, 2002). Remembered information has the “flavor” of the original experience, whereas known information is simply factual. However, although most subjects can make the remember/know distinction, its meaning is not clear. The “remember” judgment may possibly indicate a larger amount of information or its greater vividness rather than (or in addition to) a different type of recollection.

Imaging studies have shown that recalling episodic memories activates different brain regions than recalling semantic memories. Recalling episodic memories involves the right frontal region of the brain, whereas recalling semantic memories is more left frontal (Tulving et al., 1994; Cabeza et al., 1997). Furthermore, a patient with difficulty in recalling episodic memories showed a focal lesion in the right frontal region (Levine et al., 1998).

Recent imaging studies have implicated that the recall of episodic information involves complex interactions between several different regions of the brain, most particularly the hippocampi, the anterior prefrontal cortex and the left parietal cortex (Vilberg & Rugg, 2009; Rugg and Vilberg, 2013).

Tulving considered episodic memory to be a special development in human beings. Animals

have minds, they are conscious of their world, and they rely as much on learning and memory in acquiring the skills needed for survival as we do ... but they do not seem to have the same kind of ability humans do to travel back in time in their own minds (Tulving 2002).

However, human semantic memory, organized in large part through language, is also quite distinct from the memory that animals have for facts. Since it carries with it human culture, art, science, and history, our semantic memories are

every bit as special as our memories of personal experience.

Everything that we learn occurs initially part of a subjective experience. How experience becomes memory is not clear. Semantic memories may derive from episodic memories after they have been separated from their personal associations through processes such as inference, abstraction, generalization or consolidation. However, it is also possible that the initial experience is stored simultaneously in the two types of memory.

### **Autobiographical Memory**

Autobiographical memory is composed of both semantic and episodic elements (Conway & Pleydell-Pearce, 2000; Renoult et al., 2012). I can recall the names of my family members, the important dates of my life (birth, graduation, marriage), and the sequence of places where I have lived or worked in much the same way that I recall the capitals of countries. Yet I can also recall my actual experiences during my wedding or my first day at work. The story of my life can thus be viewed at different levels: in semantic outline or episodic detail.

Episodic memories are generally organized around the idea of a person that persists from one episode to the next (Picton, 2012). As well as linking together what has happened to us into a personal history, our autobiographical memory also contains explanations for why we did what we did. Thus we come to know how we tend to respond in certain situations, what needs and desires govern our actions, and what goals we might be aiming for. Thus we develop a sense of self:

When it comes to our identities, narrative is not only *about* self, but is rather in some profound way a constituent part *of* self (Eakin, 2008, p. 2).

This psychological concept of the person shows some similarities to the existentialist view of the man as not being endowed with a soul but as having to create one out of

nothing:

Freedom is precisely the nothingness which is made to be at the heart of man and which forces human reality to make itself instead of to be. As we have seen, for human reality, to be is to choose oneself; nothing comes to it from the outside or from within which it can receive or accept. Without any help whatsoever, it is entirely abandoned to the intolerable necessity of making itself be. (Sartre, 1943/1995, p. 485, translation Barnes)

We can be quite creative in how we put together our personal story:

we are all virtuoso novelists, who find ourselves engaged in all sorts of behavior, more or less unified, but sometimes disunified, and we always put the best 'faces' on it we can. We try to make all of our material cohere into a single good story. And that story is our autobiography. The chief fictional character at the center of that autobiography is one's *self*. (Dennett, 1992).

Unfortunately, we are sometimes unreliable narrators. When we are happy we can see our lives as the successful outcome of our intelligence, charm and drive. When we are depressed we may misperceive what has happened and exaggerate our personal failures. A good friend or a psychotherapist can help us by listening to our story, pointing out its inconsistencies, and suggesting different interpretations. They help us to be honest with ourselves (Coetzee & Kurtz, 2015). If our version of our life history is more fiction than fact, we can have great difficulty handling the present or coping with the future.

The concept of a personal narrative is often associated with morality. Should we not be responsible for the story of our life in some manner? "Accountable" was the word used by Locke in his discussion of the person. Charles Taylor remarks

[I]n order to make minimal sense of our lives, in order to have an identity, we need an orientation to the good, which means some sense of qualitative discrimination, of the incomparably higher. Now we see that this sense of the good has to be woven into my understanding of my life as an unfolding story. (Taylor, 1989, p. 47)

Alasdair MacIntyre (1984) has also considered personal identity and its relation to ethics:

In what does the unity of an individual life consist? The answer is that its unity is the unity of a narrative embodied in a single life. To ask 'What is the good for me?' is to ask how best I might live out that unity and bring it to completion. (MacIntyre, 1984, p. 218)

He goes on to describe the personal narrative in terms of a "quest" for the good. We seek to go from the as yet unfulfilled present person to a future person as he could be if he were to realize his essential nature (MacIntyre, 1984, p. 52).

## **Memory Style**

Recent studies have indicated that some subjects have autobiographical memories that are more highly developed than normal subjects (Leport et al., 2012). These patients can recall much more about what occurred during their lives than normal subjects. When prompted by specific dates they can often recall exactly what they were doing and what was happening in the world. These subjects organized their autobiography using a strict chronological ordering.

Other subjects have a much less developed autobiographical memory than normal (Palombo et al., 2015). These subjects experience much less episodic detail when they recall their past particularly from childhood and adolescence. For the more recent past, the subjects appear to compensate, perhaps by using semantic memory to encode what others would maintain as

episodic details. During remember/know recognition-testing, the subjects reported remember judgments much less frequently than control subjects. It is as though they have some deficit in either making or recalling episodic memories. However, it is difficult to evaluate this by asking them about their experience. This would be like asking a color-blind patient to describe his experience of red. On physiological testing, the subjects showed reduced activation in the brain regions normally associated with episodic recall.

These two groups of subjects may represent the limits of normal variability in memory styles. In this regard it is interesting to note some recent contributions from philosophy. Galen Strawson (2004, 2012) has proposed that there are two kinds of self-experience: diachronic and episodic. A diachronic (from the Greek *dia* through and *chronos* time) person considers himself or herself as an entity that has persisted from past to present and that will continue into the future. Most diachronic persons consider their past in terms of a personal narrative. An episodic (from the Greek *epi* in addition and *eisodos* entrance) person is one who has little or no sense of a past or future identity, and little concern with his or her life story. The memory of the personal past is discontinuous and divorced from the present self. Strawson considers himself as episodic:

I have a past, like any human being, and I know perfectly well that I have a past. I have a respectable amount of factual knowledge about it, and I also remember some of my past experiences 'from the inside', as philosophers say. And yet I have absolutely no sense of my life as a narrative with form, or indeed as a narrative without form. Absolutely none. Nor do I have any great or special interest in my past. Nor do I have a great deal of concern for my future. (Strawson, 2004, p. 433)

Strawson's use of "episodic" is different (indeed almost the opposite) from Tulving's. Strawson uses it to describe a

person who considers the past (and future) as having little relation to the present, whereas Tulving uses it to describe the experiential quality of remembering. The term "episodic" has been used with even other meanings: Donald (2001, pp. 200-202) uses it to describe the temporal organization of experience into meaningful events.

Strawson proposes that episodic persons are not that uncommon. Since such persons would generally not write autobiographies, the historical record may be biased towards the diachronic. Strawson nevertheless quotes others who share his episodic nature. Goronwy Rees (1961) entitled his autobiography *A Bundle of Sensations*. The title makes allusion to David Hume, who was himself sceptical about the possibility of any person or perceiving subject. He considered each of us to be

nothing but a bundle or collection of different perceptions, which succeed each other with an inconceivable rapidity, and are in a perpetual flux and movement. Our eyes cannot turn in their sockets without varying our perceptions. Our thought is still more variable than our sight; and all our other senses and faculties contribute to this change; nor is there any single power of the soul, which remains unalterably the same, perhaps for one moment. (Hume, 1738, Book I Part IV Section VI)

Strawson's main point, however, is to criticize the idea that a personal narrative is essential to moral development. Indeed because of the way that it is continually revised, a deeply experienced personal narrative may hinder more than help:

the Narrative tendency to look for story or narrative coherence in one's life is, in general, a gross hindrance to self-understanding: to a just, general, practically real sense, implicit or explicit, of one's nature. It's well known that telling and retelling one's past leads to changes, smoothings, enhancements, shifts away from the facts ... The implication is plain: the more you recall,

retell, narrate yourself, the further you risk moving away from accurate self-understanding, from the truth of your being. (Strawson, 2004, p. 447).

Eakin (2008) has argued against Strawson's dissociation of personal identity from any narrative evaluation of one's past and future. It may all depend on the way in which the memory of the past is organized. Not all stories are told from beginning to end. As Christman (2004) has pointed out the events in a narrative may be linked according to causal connections (from the beginning), teleological directions (toward the end) or thematic relations (interacting foci).

What the condition of narrativity amounts to, then, is the more basic requirement that the person must be able to look upon the factors and events of her life with a certain interpretive reflection, whether or not those factors and events have any particular narrative unity in a traditional sense. Christman (2004).

## **Person and Memory**

A person is an entity with a unique [point of view](#) that can be exercised in both space and time. From this particular perspective a person can perceive the present world, remember the past and speculate about the future.

Persons differ on how they view the relation between themselves and the world. Some live mainly for the present and have little relationship to their past. Indeed they may even feel that their past self was a different person from their present self. They may have difficulty recalling the experience of a past episodes in their lives even though they know that they occurred. Others pay particular attention to what has happened to them and how they might approach the future. They are intensely interested in how their life develops over time.

Whether such differences are the result of the normal

variability of human memory systems or the result of a deficiency in some neural process or processes remains an open question. We need to find out how episodic memories are generated in the brain and how they differ from semantic memories. How differences in memory style relate to differences in personality also needs investigation. For example, are diachronics more likely to be introverted than extraverted?

## **Omphale**

The posting concludes with a [photograph](#) of the statue of [Omphale](#) in the Schönbrunn Garden in Vienna. The photograph was taken by Manfred Werner using a flash, during a summer night-time concert of the Vienna Philharmonic.

For three years Hercules was Omphale's slave and lover. At times they exchanged their clothing. In the statue Omphale wears Hercules lion-skin and carries his club. The photograph is formally very similar to the photograph of Clio at the beginning of this post. Yet for me they differ in much the same way as semantic and episodic memory. Clio is abstract and put together after the fact. Omphale is an experience.

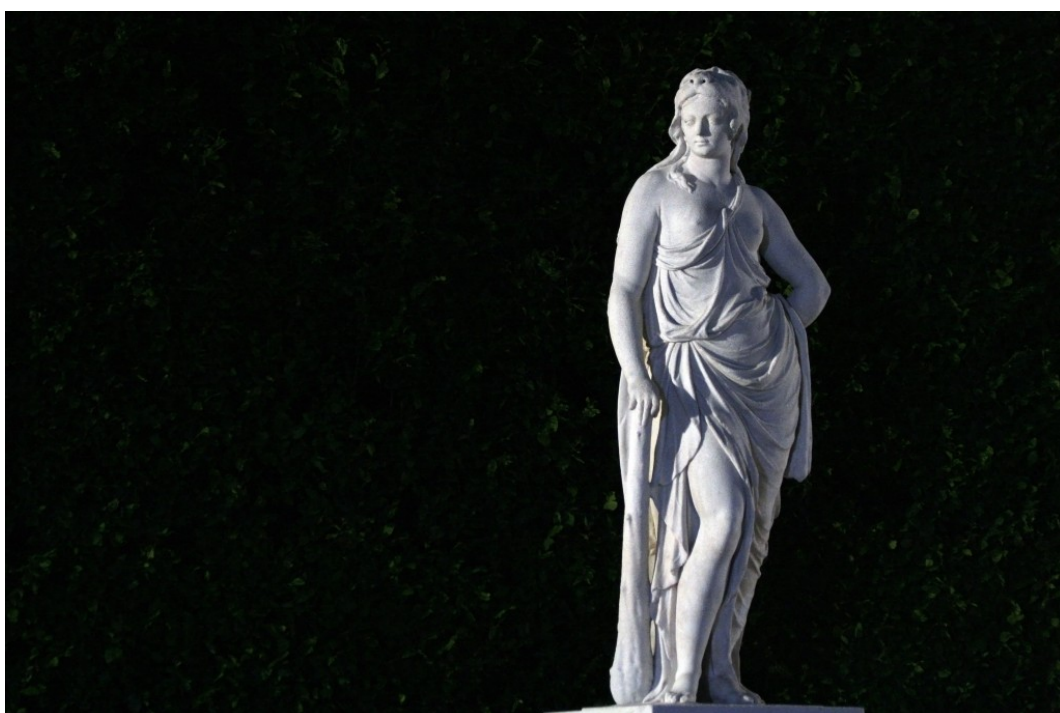



## References

Behan, D. (1979). Locke on persons and personal identity. *Canadian Journal of Philosophy*, 9, 53–75.

Christman, J. (2004). Narrative unity as a condition of personhood. *Metaphilosophy*, 35, 695–713.

Coetzee, J. M., & Kurtz, A. (2015). *The good story: Exchanges on truth, fiction and psychotherapy*. London: Harvill Secker.

Condillac, E. B. de (1746). [Essai sur l'origine des connaissances humaines](#). Available at Université de Québec à Chicoutimi.

La liaison de plusieurs idées ne peut avoir d'autre cause que l'attention que nous leur avons donnée, quand elles se sont présentées ensemble: ainsi les choses n'attirant notre attention que par le rapport qu'elles ont à notre tempérament, à nos passions, à notre état, ou, pour tout dire en un mot, à nos besoins.

Lorsque les objets attirent notre attention, les perceptions qu'ils occasionnent en nous, se lient avec le sentiment de notre être et avec tout ce qui peut y avoir quelque rapport. De là il arrive que non seulement la conscience nous donne connaissance de nos perceptions, mais encore, si elles se répètent, elle nous avertit souvent que nous les avons déjà eues, et nous les fait connaître comme étant à nous, ou comme affectant, malgré leur variété et leur succession, un être qui est constamment le même *nous*. La conscience, considérée par rapport à ces nouveaux effets, est une nouvelle opération qui nous sert à chaque instant et qui est le fondement de l'expérience. Sans elle chaque moment de la vie nous paraît le premier de notre existence, et notre connaissance ne s'étendrait jamais au-delà d'une première perception: je la nommerai *réminiscence*.

Condillac, E. B. de (1754). [\*Traité des sensations\*](#). Available at Université de Québec à Chicoutimi.

[J]e me vois, je me touche, en un mot, je me sens, mais je ne sais ce que je suis.

Dennett, D. C. (1992). [\*The self as a center of narrative gravity\*](#). In: F. Kessel, P. Cole & D. Johnson (eds.) *Self and consciousness: Multiple perspectives*. (pp 102-115) Hillsdale, NJ: Erlbaum

Donald, M. (2001). *A mind so rare: The evolution of human consciousness*. New York: Norton.

Eakin, P. J. (2008). *Living autobiographically. How we create identity in narrative*. Ithaca, NY: Cornell University Press.

Falkenstein, L. (2010) [\*Étienne Bonnot de Condillac\*](#). *Stanford Encyclopedia of Philosophy*.

Hume, D. (1738). [\*Treatise of Human Nature\*](#). London: John Noon. Available at Project Gutenberg.

Kaitaro, T. (2007). Memory, imagination and language in eighteenth-century French sensualism. *Cortex*, 43, 651-657.

LePort, A. K., Mattfeld, A. T., Dickinson-Anson, H., Fallon, J. H., Stark, C. E., Kruggel, F., & McGaugh, J. L. (2012). Behavioral and neuroanatomical investigation of Highly Superior Autobiographical Memory (HSAM). *Neurobiology of Learning and Memory*, 98, 78–92.

Levine, B., Black, S. E., Cabeza, R., Sinden, M., McIntosh, A. R., Toth, J. P. Stuss, D. T. & Tulving, E. (1998). Episodic memory and the self in a case of isolated retrograde amnesia. *Brain*, 121, 1951–1973.

Locke, J. (1689/1694). [\*An essay concerning human understanding\*](#). 2nd Ed. London: Thomas Basset. Available at Project Gutenberg.

MacIntyre, A. C. (1981/2007). *After virtue: A study in moral theory*. 3<sup>rd</sup> Ed. Notre Dame, IN: University of Notre Dame Press.

Olsen, E. T. (2010). [Personal identity](#). *Stanford Encyclopedia of Philosophy*.

Palombo, D. J., Alain, C., Söderlund, H., Khuu, W., & Levine, B. (2015). Severely deficient autobiographical memory (SDAM) in healthy adults: A new mnemonic syndrome. *Neuropsychologia*, 72, 105–118

Parfit, D. (1984). *Reasons and Persons*. Oxford: Oxford University Press.

Parfit, D. (1984). *Reasons and Persons*. Oxford: Oxford University Press

Picton, T. W. (2012). The necessary narrative. In B. Levine and F. I. M. Craik (Eds.) *Mind and the frontal lobes. Cognition, Behavior and Brain Imaging*. (pp. 264-278). New York: Oxford University Press.

Rees, G. (1961). *A bundle of sensations: Sketches in autobiography*. New York: Macmillan

Renoult, L., Davidson, P.S., Palombo, D.J., Moscovitch, M., & Levine, B. (2012). Personal semantics: at the crossroads of semantic and episodic memory. *Trends in Cognitive Science*, 16, 550–558.

Rugg, M.D. & Vilberg, K.L. (2013). Brain networks underlying episodic memory retrieval. *Current Opinion in Neurobiology*, 23, 255-260.

Sartre, J.-P. (1943, corrigée avec index par A. Elkaim-Sartre, 1995). *L'ê tre et le ne ´ant: Essai d'ontologie phe ´nome ´nologique*. Paris: Librairie Gallimard (Editions Tel). English translation by H. Barnes is reprinted by Washington Square Press (1956/1984).

La liberté, c'est précisément le néant qui est été au Coeur de l'homme et qui contraint la réalité humaine à se faire, au lieu d'être. Nous l'avons vu, pour la la réalité humaine, être c'est se choisir: rien ne lui vient du dehors, ni du dedans non plus, qu'elle puisse recevoir ou accepter. Elle est entièrement abandonnée, sans aucune aide d'aucune sorte, à l'insoutenable nécessité de se faire être jusque dans le moindre détail.

Strawson, G. (2004). Against narrativity. *Ratio*, 17, 428–451.

Strawson, G. (2012). "We live beyond any tale that we happen to enact." *Harvard Review of Philosophy*, 18, 73-90.

Taylor, C. (1985). *Philosophical Papers. Volume 1. Human agency and language*. Cambridge UK: Cambridge University Press. (Chapter 4. The concept of a person. pp. 97-114).

Taylor, C. (1989). *Sources of the self: The making of the modern identity*. Cambridge, MA: Harvard University Press.

Tulving, E. (1972). Episodic and semantic memory. In E. Tulving & W. Donaldson, (Eds.) *Organization of Memory*. (pp. 381–403). New York: Academic Press.

Tulving, E. (1983). *Elements of episodic memory*. Oxford: Clarendon Press.

Tulving, E. (2002). Episodic memory: from mind to brain. *Annual Review of Psychology*, 53, 1–25.

Vilberg, K.L., & Rugg, M.D. (2009). Functional significance of retrieval-related activity in lateral parietal cortex: Evidence from fMRI and ERPs. *Human Brain Mapping*, 30, 1490-501.

Wellman, H. M. (2011) Developing a theory of mind. In U. Goswami (Ed.), *Handbook of Childhood Cognitive Development*, 2<sup>nd</sup> Ed. (pp. 258-284). Chichester, UK: Wiley Blackwell.

Wheeler, M. A., Stuss, D. T., & Tulving, E. (1997). Toward a theory of episodic memory: the frontal lobes and autonoetic consciousness. *Psychological Bulletin*, 121, 331–354.